

**check valve, screw-in type
manual operated
POCI-12.-M-0-..**



Symbol:

Nom. pressure:
350 bar

Nominal flow:
130 l/min.

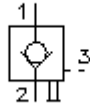

IMAV-Hydraulik GmbH
Breite Strasse 10
D-40670 Meerbusch (Osterath)
Phone +49 (0)2159 - 9188.0
Fax +49 (0)2159 - 4242
E-mail: info@imav.com
Internet: <http://www.imav.com>

CC-210-122-00
(Subject to change!)

HEX 1/2"

HEX 1 5/16"
(torque
cartridge:
95 - 100 Nm)

cavity:
C-12-3S
see
data-sheet no.:
[IK-200-129-00](#)

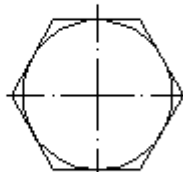
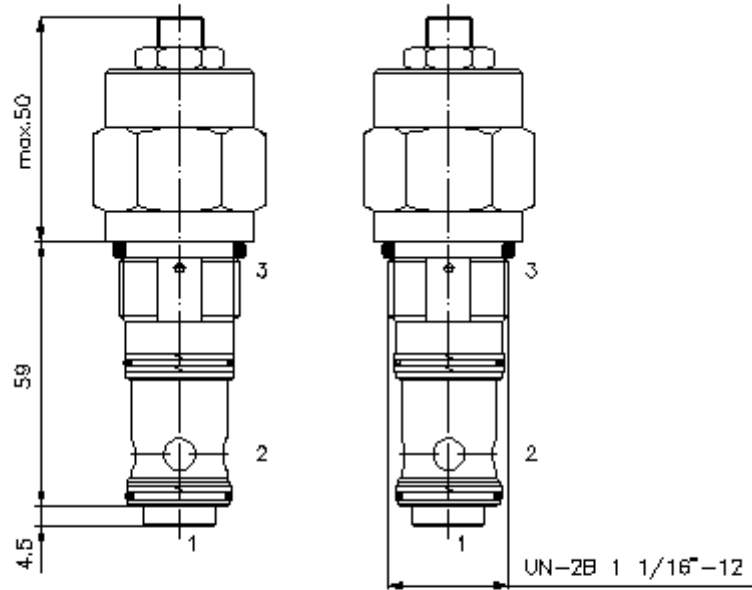

Attention:
Please see note at
data-sheet no.:
[IK-200-129-00](#) !

$\frac{\Delta p}{\text{bar}}$ Δp -Q-characteristic
at 28 cSt (50°C)

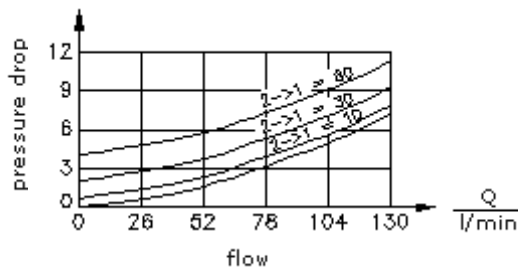

**check valve, screw-in type
manual operated
POCI-12.-M-0-..**



IMAV-Hydraulik GmbH
Breite Strasse 10
D-40670 Meerbusch (Osterath)
Phone +49 (0)2159 - 9188.0
Fax +49 (0)2159 - 4242
E-mail: info@imav.com
Internet: <http://www.imav.com>

CC-210-122-00

(Subject to change!)

Ordering example:

POCI - 12N - M - 0 - 30
| | | | |
A **B** **C** **D** **E**

Model code:

A design
check valve
pilot operated by hydraulics
pilot ratio 3 : 1

B size and sealing
12N = Buna (NBR)
12V = Viton (FPM)

C adjustment
M = manually pilot operated

D construction
0 = screw-in valve

E crack pressure
10 = 0.7 bar
30 = 2.1 bar
60 = 4.1 bar

Technical Data:

nominal pressure: 350 bar
nominal flow: 130 l/min
weight: 0.3 kg
temperature range: -40°C to 120°C
fluids: hydraulic oil as per DIN 51524 T1 (ISO TC 131)
max. leakage: 5 drops/min at 22 cSt (50°C) and 350 bar
seals: optional Buna (NBR) or Viton (FPM), as well as Teflon wascher (PTFE)
cavity: C-12-3S see datasheet no. [IK-200-129-00](#)
housing: 3SLH-12.-B.. see datasheet no. [IH-200-000-00](#)
seal kit: SP-CDS-12N-33S (NBR), SP-CDS-12V-33S (FPM)