

**check valve, screw-in type
external pilot operated
POCX-10.-0-2B-...**



Symbol:

Nom. pressure:
350 bar

Nominal flow:
70 l/min.

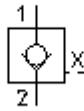

IMAV-Hydraulik GmbH
Breite Strasse 10
D-40670 Meerbusch (Osterath)
Phone +49 (0)2159 - 9188.0
Fax +49 (0)2159 - 4242
E-mail: info@imav.com
Internet: <http://www.imav.com>

CC-240-101-00
(Subject to change!)

HEX 27mm
(torque
cartridge:
48 - 54 Nm)

cavity:
C-10-2
see
data-sheet no.:
[IK-100-109-00](#)

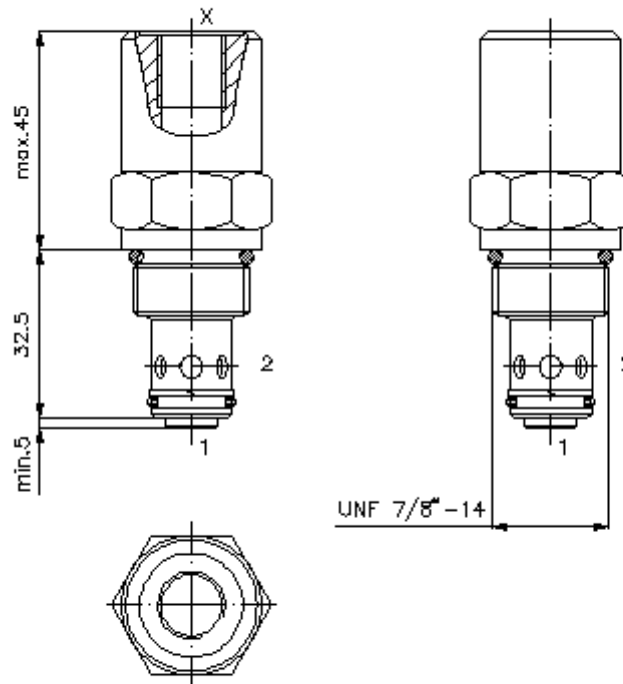

$\frac{\Delta p}{\text{bar}}$ Δp -Q-characteristic
at 28 cSt (50°C)

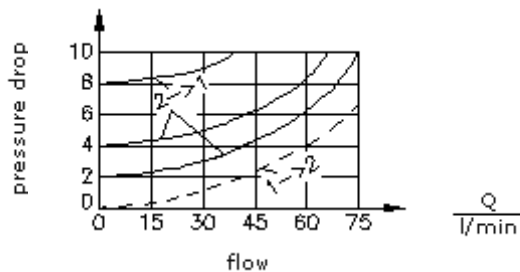

**check valve, screw-in type
external pilot operated
POCX-10.-0-2B-...**



IMAV-Hydraulik GmbH
Breite Strasse 10
D-40670 Meerbusch (Osterath)
Phone +49 (0)2159 - 9188.0
Fax +49 (0)2159 - 4242
E-mail: info@imav.com
Internet: <http://www.imav.com>

CC-240-101-00

(Subject to change!)

Ordering example:

POCX - 10N - 0 - 2B - 015
| | | | |
A **B** **C** **D** **E**

Model code:

- | | |
|---|---|
| <p>A design
check valve
pilot operated by hydraulics
pilot ratio 3 : 1</p> <p>B size and sealing
10N = Buna (NBR)
10V = Viton (FPM)</p> <p>C construction
0 = screw-in valve</p> <p>D pilot port "X"
2B = BSPP 1/4"
4T = UNF 7/16"-20</p> | <p>E crack pressure
030 = 2.1 bar
060 = 4.1 bar
090 = 6.2 bar
120 = 8.3 bar
150 = 10.3 bar
180 = 12.4 bar
210 = 14.5 bar</p> |
|---|---|

Technical Data:

- | | |
|---------------------------|--|
| note: | orifice at port "X" designated |
| nominal pressure: | 350 bar |
| nominal flow: | 70 l/min |
| weight: | 0.14 kg |
| temperature range: | -40°C to 120°C |
| fluids: | hydraulic oil as per DIN 51524 T1 (ISO TC 131) |
| max. leakage: | 5 drops/min at 22 cSt (50°C) and 350 bar |
| seals: | optional Buna (NBR) or Viton (FPM), as well as Teflon wascher (PTFE) |
| cavity: | C-10-2 see datasheet no. IK-100-109-00 |
| housing: | 2LH-10.-B.. see datasheet no. IH-100-000-00 |
| seal kit: | SP-CDS-10N-21 (NBR), SP-CDS-10V-21 (FPM) |