

# 2/2 logični pokretni razvodnik tip "T" DPS2-10.-T.-0-...



**Simbol**

**Nazivni pritisak**  
350 bar

**Nazivni protok**  
60 l/min

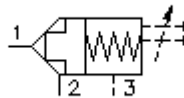

IMAV-Hydraulik GmbH  
Breite Strasse 10  
D-40670 Meerbusch (Osterath)  
Telefon +49 (0)2159 - 9188.0  
Telefax +49 (0)2159 - 4242  
E-mail: [info@imav.com](mailto:info@imav.com)  
Internet: <http://www.imav.com>

**MD-710-103-00**  
(Promjene nisu isključene!)

promjer ključa 1"

izvrtina:  
C-10-3S  
vidi  
stranicu broj:  
[IK-200-109-00](#)

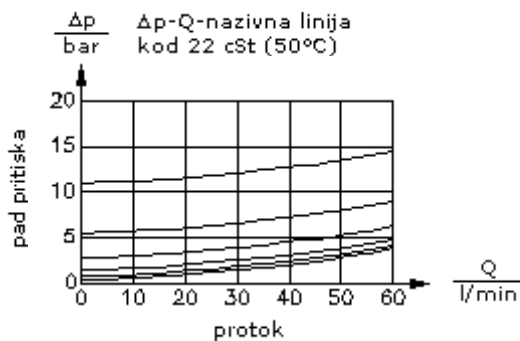
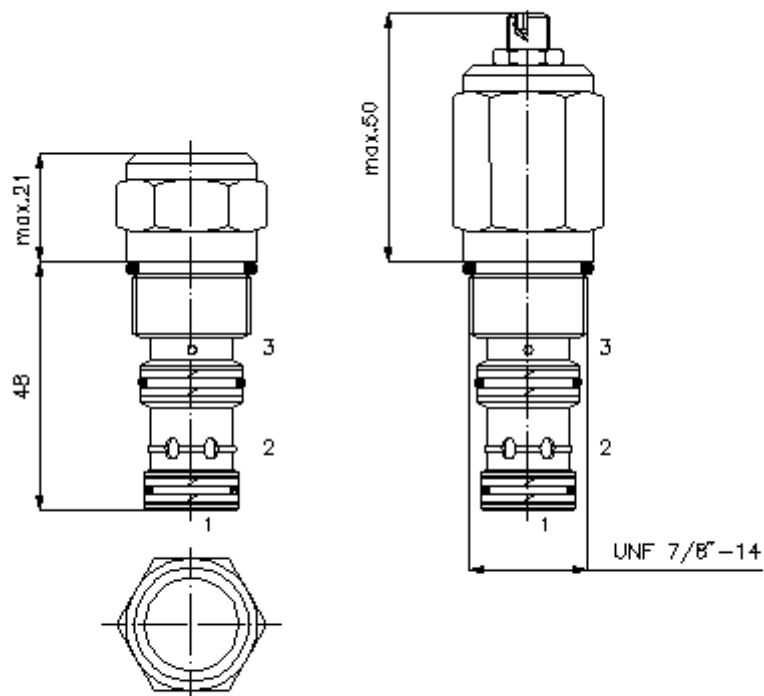

## 2/2 logični pokretni razvodnik tip "T" DPS2-10.-T.-0-...

### Primjer za porudžbu

DPS2 - 10N - T - F - 0 - 040

↓	↓	↓	↓	↓	↓
<b>A</b>	<b>B</b>	<b>C</b>	<b>D</b>	<b>E</b>	<b>F</b>



IMAV-Hydraulik GmbH  
Breite Strasse 10  
D-40670 Meerbusch (Osterath)  
Telefon +49 (0)2159 - 9188.0  
Telefax +49 (0)2159 - 4242  
E-mail: [info@imav.com](mailto:info@imav.com)  
Internet: <http://www.imav.com>

**MD-710-103-00**

(Promjene nisu isključene!)

### Ključ

- |  |   |
|--|---|
| <b>A</b> <b>izvedba</b><br>logični ventil  | <b>E</b> <b>konstrukcija</b><br>0 = uvrtni ventil   |
| <b>B</b> <b>velicina i zaptivac</b><br>10N = buna (NBR)<br>10V = viton (FPM)                       | <b>F</b> <b>pritisak za otvaranje</b><br>040 = 2,8 bar<br>080 = 5,5 bar<br>160 = 11,0 bar |
| <b>C</b> <b>tip klipa</b><br>T = dvostrano upravljanje za zatvaranje<br>osnovna pozicija zatvorena |   |
| <b>D</b> <b>vrsta podesavanja</b><br>F = fiksno<br>S = ograničenje hoda                            |   |

### Tehnicke informacije

<b>nazivni pritisak:</b>	350 bar
<b>nazivni protok:</b>	60 l/min
<b>težina:</b>	0,14 kg
<b>područje temperature:</b>	-40°C do 120°C
<b>medium:</b>	hidraulično ulje po DIN 51524 T1 (ISO TC 131)
<b>max. curenje:</b>	1 -> 2 = 5 kapi/min kod 22 cSt (50°) i 350 bar
<b>opcija:</b>	opcionalno Buna (NBR) ili Viton (FPM), kao i teflon metalni prsten (PTFE)
<b>odnos otvaranja:</b>	2 : 1
<b>uvrtina:</b>	C-10-3S vidi stranicu broj: <a href="#">IK-200-109-00</a>
<b>kuciste:</b>	3SLH-10.-B.. vidi stranicu broj: <a href="#">IH-200-000-00</a>
<b>komplet zaptivaca:</b>	SP-MDS-10N-34S (NBR), SP-MDS-10V-34S (FPM)