

**prigusni uvrtni ventil
(podesivi)
FCV7-10.-.-0-NV.**



Simbol

Nazivni pritisak
210 bar

Nazivni protok
45 l/min

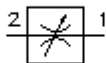

IMAV-Hydraulik GmbH
Breite Strasse 10
D-40670 Meerbusch (Osterath)
Telefon +49 (0)2159 - 9188.0
Telefax +49 (0)2159 - 4242
E-mail: info@imav.com
Internet: <http://www.imav.com>

MF-410-100-00
(Promjene nisu isključene!)

promjer kljuca
3/4"

promjer kljuca 1"
(stezni
obrotni moment:
48 - 54 Nm)

izvrtina
C-10-2
vidi
stranicu broj:
IK-100-109-00

velicina kljuca
3/16"

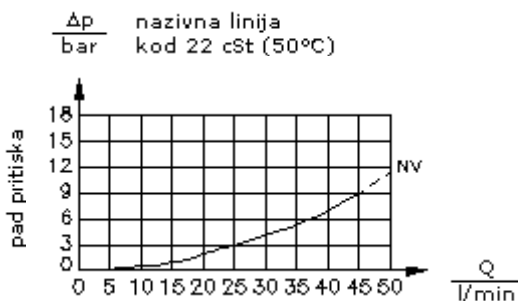
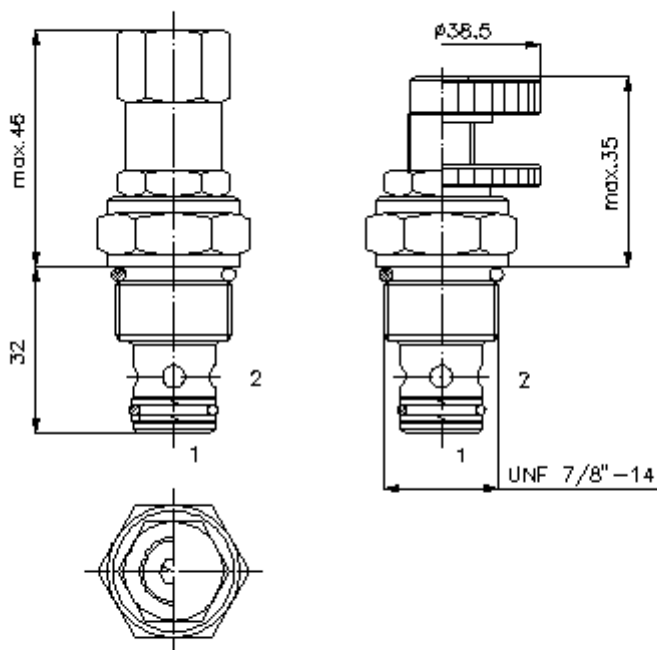

ogranicenje 1>3

reduciranje 2>1

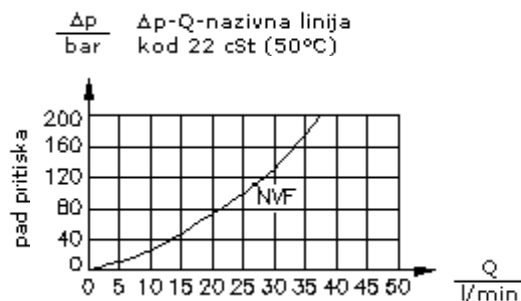

protok

**prigusni uvrtni ventil
(podesivi)
FCV7-10.-.-0-NV.**

Primjer za porudzbu

FCV7 - 10N - C - 0 - NV
| | | | |
A **B** **C** **D** **E**



IMAV-Hydraulik GmbH
Breite Strasse 10
D-40670 Meerbusch (Osterath)
Telefon +49 (0)2159 - 9188.0
Telefax +49 (0)2159 - 4242
E-mail: info@imav.com
Internet: <http://www.imav.com>

MF-410-100-00
(Promjene nisu isključene!)

Kljuc

- | | |
|--|--|
| A izvedba
prigusni ventil | D konstrukcija
0 = uvrtni ventil |
| B velicina i zaptivac
10N = buna (NBR)
10V = viton (FPM) | E tip prigusivanja
NV = prigusni uvrtni ventil
NVF = fini prigusni uvrtni ventil |
| C vrsta podesavanja
S = vreteno sa zavojnicom
C = cep
K = rucni tocak | |

Tehnicke informacije

nazivni pritisak: 210 bar
nazivni protok: 45 l/min
tezina: 0,11 kg
podrucje temperature: -40°C do 120°C
medium: hidraulicno ulje po DIN 51524 T1 (ISO TC 131)
max. curenje: 5 kapi/min kod 22 cSt (50°C) i 210 bar
opcija: opcionalno Buna (NBR) ili Viton (FPM), kao i teflon metalni prsten (PTFE)
uvrtina: C-10-2 vidi stranicu broj: [IK-100-109-00](#)
kuciste: 2LH-10.-B.. vidi stranicu broj: [IH-100-000-00](#)
komplet zaptivaca: SP-MDS-10N-22 (NBR), SP-MDS-10V-22 (FPM)