

**prigusni uvrtni ventil
(podesivi)
FCV11-12.-.-0-NV**



Simbol

Nazivni pritisak
350 bar

Nazivni protok
114 l/min

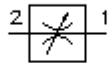

IMAV-Hydraulik GmbH
Breite Strasse 10
D-40670 Meerbusch (Osterath)
Telefon +49 (0)2159 - 9188.0
Telefax +49 (0)2159 - 4242
E-mail: info@imav.com
Internet: <http://www.imav.com>

MF-420-121-00
(Promjene nisu isključene!)

promjer kljuca 1
1/4"

izvrtina:
C-12-2
vidi
stranicu broj:
IK-100-129-00

promjer kljuca
1/8"

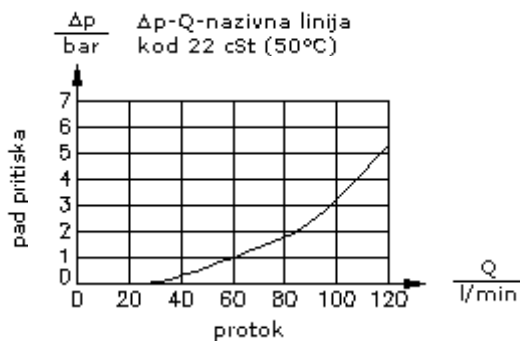
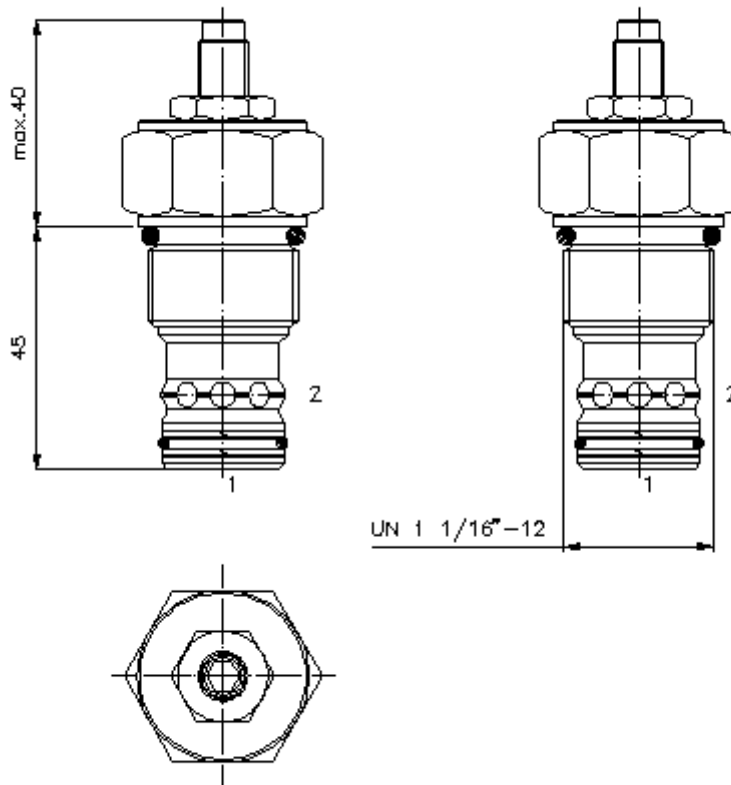

**prigusni uvrtni ventil
(podesivi)
FCV11-12.-.-0-NV**

Primjer za porudzbu

FCV11 - 12N - S - 0 - NV
| | | | |
A **B** **C** **D** **E**



IMAV-Hydraulik GmbH
Breite Strasse 10
D-40670 Meerbusch (Osterath)
Telefon +49 (0)2159 - 9188.0
Telefax +49 (0)2159 - 4242
E-mail: info@imav.com
Internet: <http://www.imav.com>

MF-420-121-00
(Promjene nisu isključene!)

Kljuc

- | | |
|--|---|
| A izvedba
prigusni ventil | C vrsta podesavanja
S = vreteno sa zavojnicom |
| B velicina i zaptivac
12N = buna (NBR)
12V = viton (FPM) | D konstrukcija
0 = uvrtni ventil |
| | E tip prigusivanja
NV = prigusni uvrtni ventil |

Tehnicke informacije

nazivni pritisak: 350 bar
nazivni protok: 114 l/min
tezina: 0,24 kg
podrucje temperature: -40°C do 120°C
medium: hidraulicno ulje po DIN 51524 T1 (ISO TC 131)
max. curenje: 5 kapi/min kod 22 cSt (50°C) i 210 bar
opcija: opcionalno Buna (NBR) ili Viton (FPM), kao i teflon metalni prsten (PTFE)
uvrtina: C-12-2 vidi stranicu broj: [IK-100-129-00](#)
kuciste: 2LH-12.-B.. vidi stranicu broj: [IH-100-000-00](#)
komplet zaptivaca: SP-MDS-12N-22 (NBR), SP-MDS-12V-22 (FPM)