

**prigusni uvrtni ventil
(podesivi)
FCV6-16.-.-0-NV**



Simbol

Nazivni pritisak
210 bar

Nazivni protok
208 l/min

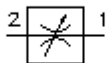

IMAV-Hydraulik GmbH
Breite Strasse 10
D-40670 Meerbusch (Osterath)
Telefon +49 (0)2159 - 9188.0
Telefax +49 (0)2159 - 4242
E-mail: info@imav.com
Internet: <http://www.imav.com>

MF-430-160-00
(Promjene nisu isključene!)

promjer kljuca
3/4"

promjer kljuca 1
1/2"
(stezni
obrotni moment:
109 - 122 Nm)

izvrtina:
C-16-2
vidi
stranicu broj:
IK-100-169-00

velicina kljuca
3/16"

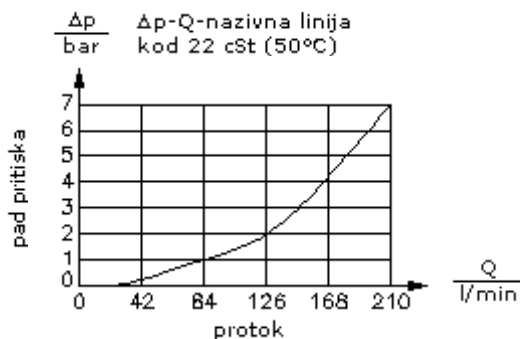
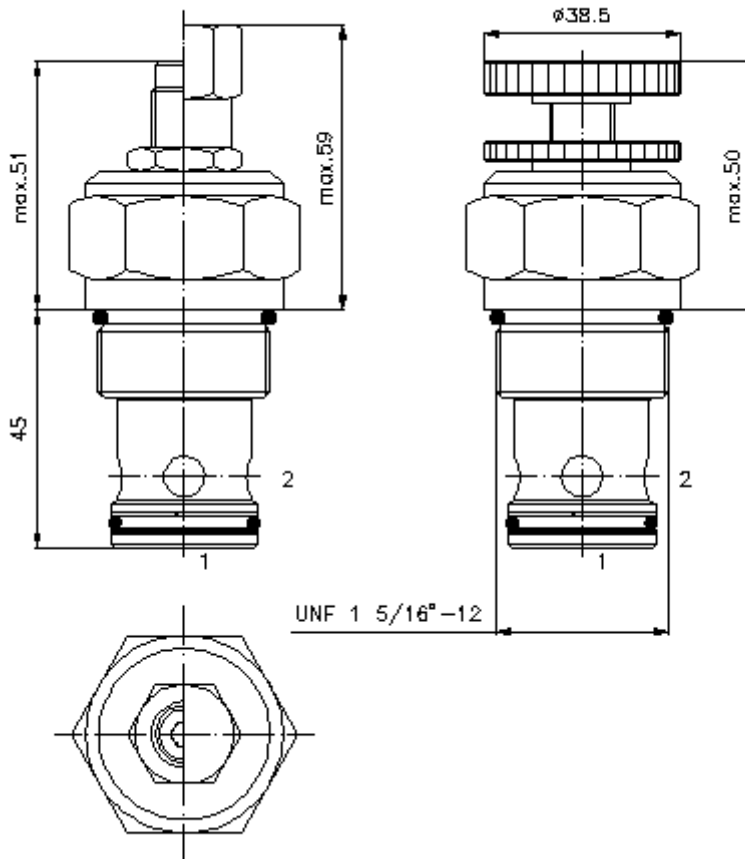

**prigusni uvrtni ventil
(podesivi)
FCV6-16.-0-NV**

Primjer za porudzbu

FCV6 - 16N - C - 0 - NV
| | | | |
A **B** **C** **D** **E**



IMAV-Hydraulik GmbH
Breite Strasse 10
D-40670 Meerbusch (Osterath)
Telefon +49 (0)2159 - 9188.0
Telefax +49 (0)2159 - 4242
E-mail: info@imav.com
Internet: <http://www.imav.com>

MF-430-160-00

(Promjene nisu isključene!)

Kljuc

- | | |
|--|---|
| A izvedba
prigusni ventil | D konstrukcija
0 = uvrtni ventil |
| B velicina i zaptivac
16N = Buna (NBR)
16V = viton (FPM) | E tip prigusivanja
NV = prigusni uvrtni ventil |
| C vrsta podesavanja
S = vreteno sa zavojnicom
C = cep
K = rucni tocak | |

Tehnicke informacije

nazivni pritisak:	210 bar
nazivni protok:	208 l/min
tezina:	0,37 kg
podrucje temperature:	-40°C do 120°C
medium:	hidraulicno ulje po DIN 51524 T1 (ISO TC 131)
max. curenje:	5 kapi/min kod 22 cSt (50°C) i 210 bar
opcija:	opcionalno Buna (NBR) ili Viton (FPM), kao i teflon metalni prsten (PTFE)
uvrtina:	C-16-2 vidi stranicu broj: IK-100-169-00
kuciste:	2LH-16.-B.. vidi stranicu broj: IH-100-000-00
komplet zaptivaca:	SP-MDS-16N-22 (NBR), SP-MDS-16V-22 (FPM)